

INSTRUCTION MANUAL
FOR
B & K-PRECISION
MODEL 1601
SOLID STATE
REGULATED DC POWER SUPPLY

BK PRECISION DYNASCAN
CORPORATION

6460 West Cortland Street

Chicago, Illinois 60635

CONTENTS

	Page
SPECIFICATIONS	3
FEATURES	3
INTRODUCTION	4
CONTROLS AND INDICATORS	4
OPERATING INSTRUCTIONS	5
APPLICATIONS	6
General	6
Electronic Servicing	6
Servicing Battery Operated Equipment	6
Servicing Vehicular Electronics Equipment	7
Servicing Plug-In Modules	9
Using Two Power Supplies For Two Output Voltages	9
Two Power Supplies In Series For 0-100 Volt Output	9
Using The Power Supply As A Battery Charger	10
Other Servicing Applications	
Electronics Manufacturing	10
Electronics Design Engineering	11
Electronics Education	11
CIRCUIT DESCRIPTION	12
MAINTENANCE	14

SPECIFICATIONS

OUTPUT VOLTAGE	O-50 VDC, continuously variable. Two ranges, 0-25 and 0-50 VDC.	LINE REGULATION	Maximum 0.1%. 0.02% typical, at output Voltage of 50 VDC and output current of 2 amps from 105-125 VAC.
OUTPUT CURRENT	0-2 amperes. Four ranges: 0-50 mA, 0-0.2A, 0-0.5A, and 0-2A.	RIPPLE	5 millivolts peak-to-peak maximum.
CURRENT LIMIT ADJUSTMENT	5% to 100% of each current range.	CURRENT DERATING	.02 A/°C above 25° C ambient. (2 A Range only).
LOAD REGULATION	Maximum 0.1%. typical 0.07%.	SIZE	14 1/8" x 37/8" x 10" deep.
		NET WEIGHT	11 lbs.

FEATURES

FULLY SOLID STATE	Uses integrated circuits, silicon transistors and diodes, and an SCR. All the advantages of solid state construction are utilized, including: Dependability-reliability No warm up time or stabilization delay Ruggedness Compact size	FOUR CURRENT METER RANGES	Provides maximum meter resolution. Selection of meter range also selects coarse current limit setting.
CURRENT LIMITING/ OVERLOAD PROTECTION	Protects load and instrument against overload. Current limit is fully adjustable from approximately 2.5 mA to 2 A. The power supply automatically shuts down and the OVERLOAD lamp lights if the preset current limit is exceeded. After clearing the cause of the overload, simply push the set/reset button to restore normal operation.	TWO VOLTMETER RANGES	0-25V and 0-50V ranges provide maximum meter resolution. A mechanical stop prevents the voltage level control from exceeding approximately 25 volts when the 0-25 V range is selected.
SIMPLIFIED CURRENT LIMIT SETTING	Permits setting current limit without disturbing external load connections or output voltage settings: does not require application of short circuit to output terminals. Simply push the set/reset button and adjust the current limit while reading the setting on the current meter.	STANDBY-DC ON SWITCH	Standby mode disconnects power supply from load without disturbing voltage or current control settings.
(0-50 VDC)	Continuously adjustable over entire range with a single control; no range switching required.	ON-OFF CONTROL	On-off switch is combined with voltage level control to assure voltage setting of zero when unit is turned on.
0-2 AMPS	Divided into four ranges. Fully regulated output at all current levels.	PILOT LAMP	Lights to indicate at a glance that the unit is turned on.
DUAL METERS	Allows output voltage and current to be monitored simultaneously without switching ranges from current to voltage. Both meters have overload protection to prevent damage from incorrect range selection.	MECHANICAL PREREGULATOR	Power supply's rectifier input voltage increases in progressive steps as output voltage setting is increased. Improves efficiency; less power is converted to heat at low voltage operation.
		FLOATING OUTPUT	Permits referencing the positive or negative output to any external dc potential or ground.
		REVERSE POLARITY PROTECTION	Protects against accidental damage from reverse polarity connection to external power source.
		BINDING POSTS	Heavy duty 5-way binding posts for positive cmd negative polarity output and earth ground.
		ATTRACTIVE APPEARANCE	Modern, functional design. When more than one unit is used, units may be stacked.
		EASY TO OPERATE	All controls are identified and easy to read. Simplified operation helps prevent operator mistakes that might damage equipment.

INTRODUCTION

The B & K Precision Model 1601 Regulated DC Power Supply is a versatile, laboratory quality instrument which provides regulated dc voltage and current outputs of 0 to 50 volts and 0 to 2 amperes respectively. Its high specifications, operating ease, and special features make it an excellent choice for most applications requiring a dc power source. It is especially well suited for powering transistorized and fully solid state electronic equipment such as automobile radios and sound systems, battery operated radio receivers, portable radios, mobile citizen's band transceivers and Walkie-Talkie transceivers.

The following list is but a small sample of the most popular applications for the instrument:

- Service Technicians Powering equipment or individual circuits during testing and trouble-shooting in the service shop.
- Factory Technicians Powering complete equipments or individual assemblies during testing in the factory.
- Engineers and Laboratory Technicians Powering prototype and experimental circuits and equipments.
- Electronics Instructors and Students Laboratory exercises in basic and advanced electronics.

CONTROLS AND INDICATORS

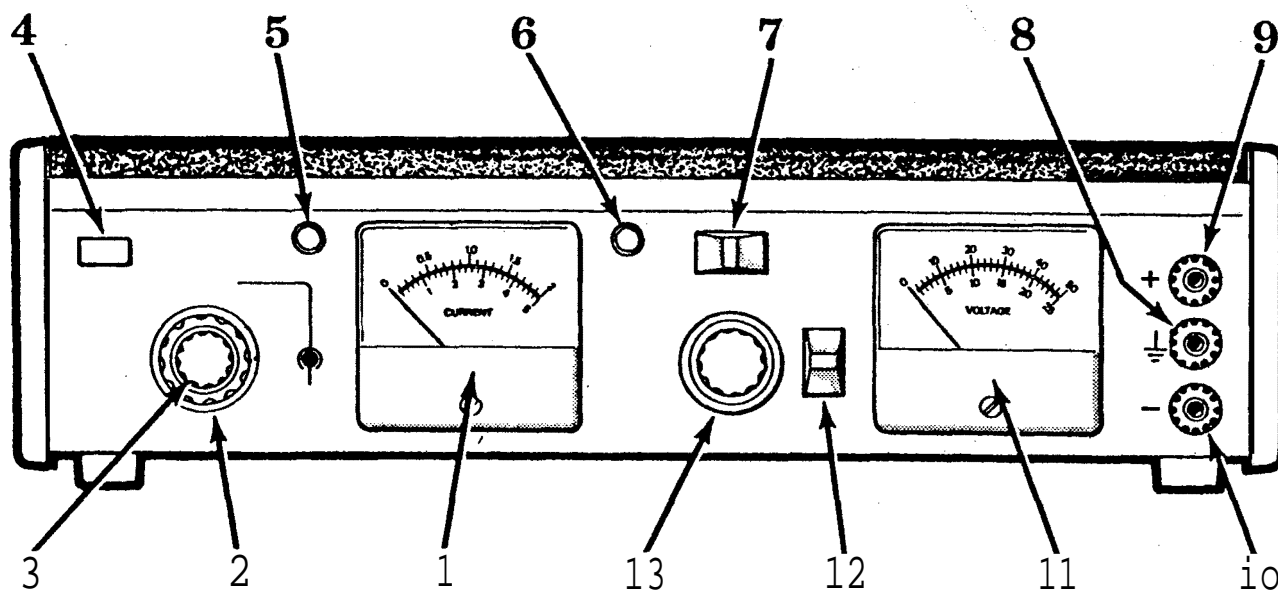

Controls and Indicators

1 current meter	Measures actual output load current during normal operation. Indicates current limit value when set/reset button 4 is pushed.	4 Push to set CURRENT LIMIT or to reset OVERLOAD button (set/reset button)	When fully depressed and held, connects current meter 1 to read the current limit setting. When pressed and released, resets overload circuit if it has been tripped.
2 CURRENT RANGE switch	Selects range for current meter 1 and coarse setting of current limit. Full scale meter reading and maximum current limit of:	5 OVERLOAD indicator (red)	Lights when current limit has been exceeded and power supply output has shut down.
0.05A position	0.05 ampere (50 milliamps)	6 POWER indicator	Lights continuously while power supply is turned on.
0.2A position	0.2 ampere (200 milliamps)	7 STBY-DCON switch;	STBY position
0.5A position	0.5 ampere (500 milliamps)	DC ON position	Removes power from output terminals 9 and 10 and voltmeter 11 but leaves power supply activated in a standby condition.
2A position	2 amperes		Applies power to output terminals 9 and 10 and voltmeter 11
3 SETCURRENT LIMIT control	Fine adjustment of current limit setting. Continuously adjustable from 5% to 100% of range which is selected by CURRENT RANGE switch 2		

8	 terminal	Earth and chassis ground terminal.
9	+ terminal	Positive polarity Output terminal.
10	- terminal	Negative polarity output terminal.
11	voltmeter	Indicates power supply output voltage.
12	METER RANGE switch	
	0-50V position	Selects full scale range of 50 volts for voltmeter 11
	0-25V position	Selects full scale range of 25 volts for voltmeter 11

and prevents LEVEL control 13 from increasing the voltage above approximately 25 volts.

13	LEVEL control	Turns off power supply at extreme counterclockwise rotation. Clockwise rotation turns on power supply and adjusts output voltage (voltage output level is not changed by the METER RANGE switch 12). Also, prevents METER RANGE switch from being set to 0-25 V position when LEVEL control is advanced beyond approximately 25 volt output.
----	---------------	---



OPERATING INSTRUCTIONS

- Turn off the power supply before plugging it into an ac outlet. Turn off by rotating the LEVEL control 13 fully counterclockwise until it "clicks" off.
- Connect the power cord to a 105-125 volt 60 Hz ac outlet.

WARNING

Use only a polarized 3-wire outlet. This assures that the power supply chassis is connected to a good earth ground and prevents danger from electrical shock. If a 2-wire to 3-wire adapter must be used, be sure the ground wire of the adapter is attached to a good earth ground.

- Turn on the power supply by rotating the LEVEL control 13 slightly clockwise past the "click". The POWER indicator 6 will light.
- Determine the maximum safe load current for the device to be powered and set the current limit for that value as follows:
 - Set the coarse current limit with the CURRENT RANGE switch 2 . When possible, select a range that provides the desired current limit at a value above 20% of the full scale reading.
 - Push and hold the set/reset button 4 while making fine current limit adjustment with the SET CURRENT LIMIT control 3 for the desired current limit as read on the current meter 1 .
 - Release the set/reset button 4 .
 - If the** maximum safe load current is unknown, start with a low current **limit** setting. If the setting is too low, the overload circuit will merely trip when power is applied to the load in steps 7 and 8. If so, increase the current limit setting in small steps until the overload circuit does not trip during normal operation.

- Set the "STBY-DC ON" switch 7 to the STBY position while connecting the test leads.
- Connect the power supply output to the device being powered with test leads as follows:
 - Connect the positive polarity input of the device being powered to the (+) terminal 9 of the power supply.
 - Connect the negative polarity input of the device being powered to the (-) terminal 10 of the power supply.
 - If the positive polarity of the device being powered is also to be ground reference, jumper the (+) terminal 9 to the () terminal 8 . If the negative polarity of the device being powered is to be ground reference, jumper the (-) terminal 10 to the () terminal 8 . If neither the positive nor negative polarity of the device being powered is to be grounded, but the chassis of the device needs grounding, connect a separate test lead from the chassis of the device to the () terminal 8 of the power supply.
- Return the "STBYDC ON" switch 7 to the DC ON position and set the output voltage as follows:
 - Set the METER RANGE switch 12 to the 0-25V position if the output voltage is to be set for 25 volts or **less**, or to the 0-50V position if the output voltage is to be set for more than 25 volts.
 - Turn LEVEL control 13 clockwise until the desired output voltage is read on the voltmeter 11 .
- If the load current exceeds the current limit, the OVERLOAD lamp 5 will light and the power supply will shut down (the current meter 1 and voltmeter 11 will drop to zero). Restore **the power** supply to normal operation as follows:

- a. To reset the power supply, press and release the set/reset button 4 . If the overload condition was intermittent, this action will restore operation.
- b. If the OVERLOAD lamp 5 remains lighted, use one of the three following techniques before resetting the power supply again:
 - Reduce the load current.
 - Reduce the voltage slightly with the LEVEL control 13 .
 - Increase the current limit slightly with the SET CURRENT LIMIT control 3 . If the normal load current is unknown, this technique may be used; but, if the current limit was already set for the maximum safe load current, do not increase the current limit further.

NOTE:

Some equipment has a highly capacitive

input which results in a surge current when power is initially applied. When powering such equipment, the overload may activate when the STBY-DC ON switch is placed in the DC ON position with full operating voltage previously set. If this occurs, reduce the voltage setting and bring it up gradually to allow the capacitors in the equipment to charge; this eliminates the surge current.

- c. If the power supply continues to shut down at the correct current limit value, check the LOAD current to determine the reason for the overload.
9. To remove power from the load without disturbing the voltage or current limiting settings, merely set the "STBY-DC ON" switch 7 in the STBY position.

APPLICATIONS

GENERAL

This instrument may be used to power a vast assortment of items in the fields of electronics servicing, electronics manufacturing, electronics design engineering and electronics education. The power supply output is fully adjustable from 0 to 50 volts, and 0 to 2 amperes. This flexibility makes it suitable for most applications requiring a dc power source.

ELECTRONICS SERVICING

The electronics technician uses the power supply as the power source for much dc and battery powered equipment being tested and serviced. It may also be used as the power source for testing modules or circuits that are removed from the equipment where it normally receives its power.

SERVICING BATTERY OPERATED EQUIPMENT

Most equipment which operates from internal batteries can be tested and serviced using this power supply as its power source. The excellent filtering characteristics makes the power supply a suitable substitute for batteries, with the added advantage that the effects of varying the voltage can be checked. The following items are among the more

common types that may be powered from this power supply:

- Portable AM or AM/FM radio receivers
- Portable short wave and multi-band radio receivers
- Portable paging receivers
- Portable monitor receivers
- Walkie Talkie type transceivers
- Portable two-way communications transceivers
- Portable cassette recorders and players
- Portable calculators
- Other battery operated electrical or electronic devices

CAUTION

Observe correct polarity. Some equipment may not contain reverse polarity protection, and may be damaged if polarities are reversed.

When servicing this type of equipment, remove the batteries and connect test leads from the (+) and (-) terminals of the power supply to the (+) and (-) power input points of the equipment being serviced as shown in Figure 1. The earth ground terminal of

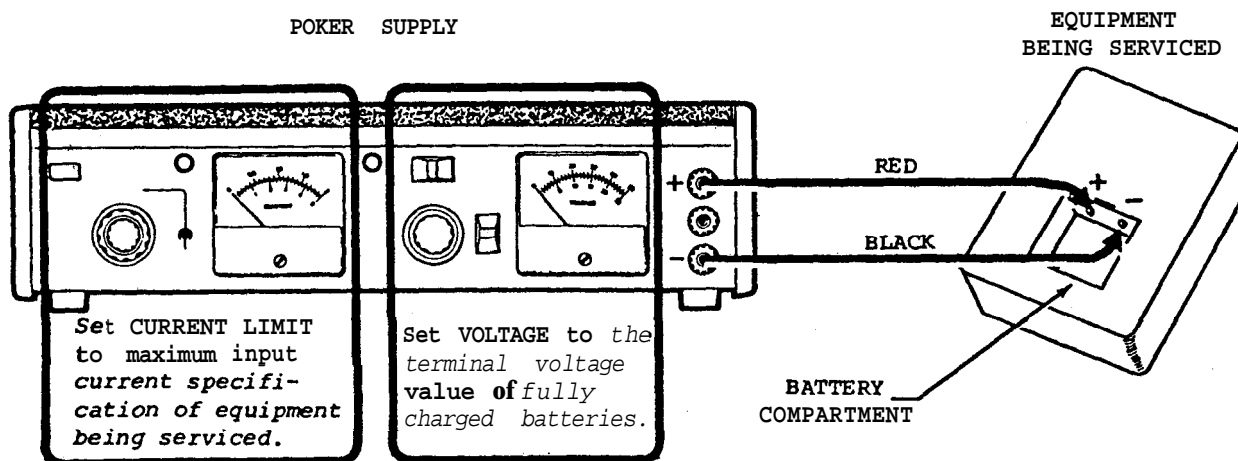

Figure 1. Typical Power Supply Connections to Battery Operated Equipment

the power supply is not normally used nor required in this application. Using separate test lead colors, such as red and black, reduces the chance of accidental **reverse** polarity connection. Set the current limit to the maximum input current specification of the equipment being serviced. If this figure is unknown, start with a low current limit and increase the setting in small increments until the overload circuit in the power supply does not trip when power is applied to the unit under test. Set the voltage to the same value that would be present if a full set of fully charged batteries were installed. Flashlight cells of all sizes are rated at 1.5 volts each. Other batteries normally state the voltage on the label, and the required operating voltage for the equipment being serviced is often stated on a label in the equipment. For units using more than one battery, check whether the batteries are connected in series or parallel. For the parallel connected arrangement, set the power supply voltage to that of a single cell; a higher voltage may damage the equipment. For the series connected arrangement, add the voltages of all cells and set the power supply voltage to that sum.

A simplified method of making connections to the power input points of battery operated equipment may be to use a "dummy" battery. A dummy battery sits in the battery compartment and makes good electrical contacts with the power input points, but has readily accessible terminals or test leads for interconnection to the power supply. The body of the dummy battery may be made from wood or other nonconductive material. The end caps must be good electrical conductors which are connected to terminals or test leads. The unit must fit snugly in the battery compartment to assure good electrical contact. An improved version may include a spring to insure a snug fit.

SERVICING VEHICULAR ELECTRONICS EQUIPMENT

When servicing electronics equipment for auto. mobiles, trucks, and other vehicles, the equipment is **normally** removed from the vehicle for bench testing. This power supply is an excellent dc power source for bench testing such equipment. The following items are among the more common types of vehicular electronics equipment that may be powered from this power supply:

AM, AM/FM and AM/FM/Stereo automobile receivers

*Tape players

Citizen's band transceivers

Monitor receivers

Automobile amateur radio receivers

*Some aircraft equipment

*Some ship-to-shore and ship-to-ship marine band transceivers

*Some vehicular two-way communications transceivers

*Some automotive amateur radio transceivers

***Maximum current 2 amperes unless special procedures are used as described in this section of the manual.**

Most automobiles and other vehicles use 12-volt electrical systems. Although the electrical system is normally referred to as a 12-volt system, actual battery voltage when fully charged is approximately 14 volts. The power supply may be set at 14 volts for servicing equipment from vehicles with 12-volt electrical systems. Some trucks use a 24-volt electrical system; bench testing of equipment from these systems should be performed at 28 volts. Aircraft normally use a 28-volt electrical system, and a bench test voltage of 32 volts is used.

Practically all vehicles use a negative ground electrical system, although a positive ground system is occasionally found. Electronic equipment which is built for use only in negative ground vehicles usually has its chassis common with the negative polarity of input power. In some cases, there is no separate negative polarity power cable, since the chassis becomes grounded when the equipment is installed in the vehicle. Some equipment is built for use in either negative or positive ground electrical systems, in which case the chassis may be isolated from both the positive and negative input polarities. There is virtually no equipment built for positive ground electrical systems only, although some electronics equipment may use its ungrounded positive polarity as reference for circuit operation.

CAUTION

Carefully observe polarity of connections. Equipment may be damaged if polarities are reversed.

When servicing this type of equipment, the (+) and (-) terminals of the power supply should be connected to the (+) and (-) power input points of the equipment being serviced with test leads. Fig-

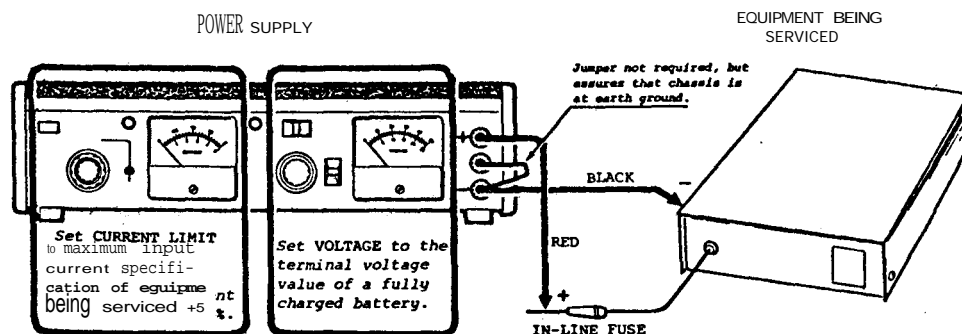

Figure 2. Typical Power Supply Connections to Vehicular Equipment (Negative Ground System, Grounded Chassis Shown)

ure 2 shows a typical example. The power supply offers overload protection; therefore, any fuse in the equipment's power cable is not required during testing. In fact, a convenient connection point may be to the fuseholder. Normally, the equipment chassis should be grounded. Usually, the negative polarity of the equipment is common with the chassis and a jumper may be connected between the ($\frac{+}{-}$) and (-) terminals of the power supply.

In those cases where the chassis is not common with the negative polarity, connect a separate test lead free from the ($\frac{+}{-}$) terminal of the power supply to the chassis of the equipment being serviced.

Figure 3 shows the proper interconnection between the power supply and the equipment under test for all possible situations.

If there is any doubt that the chassis may ~~not~~ be common with the negative polarity, use a separate ground connection from the ($\frac{+}{-}$) terminal to the equipment chassis. No damage can result if this technique is used.

Set the power supply voltage to the specification voltage for the equipment being serviced (normally the voltage value of a fully charged vehicle battery). Set the current limit to the maximum input current specification plus 5%. If specification information is unavailable, start with a moderate current limit and find the overload threshold. Increase the current limit 5% above threshold to prevent **overload** turn-off during testing. Note that most solid state receivers have a much higher load current with strong audio output. Therefore, the threshold should

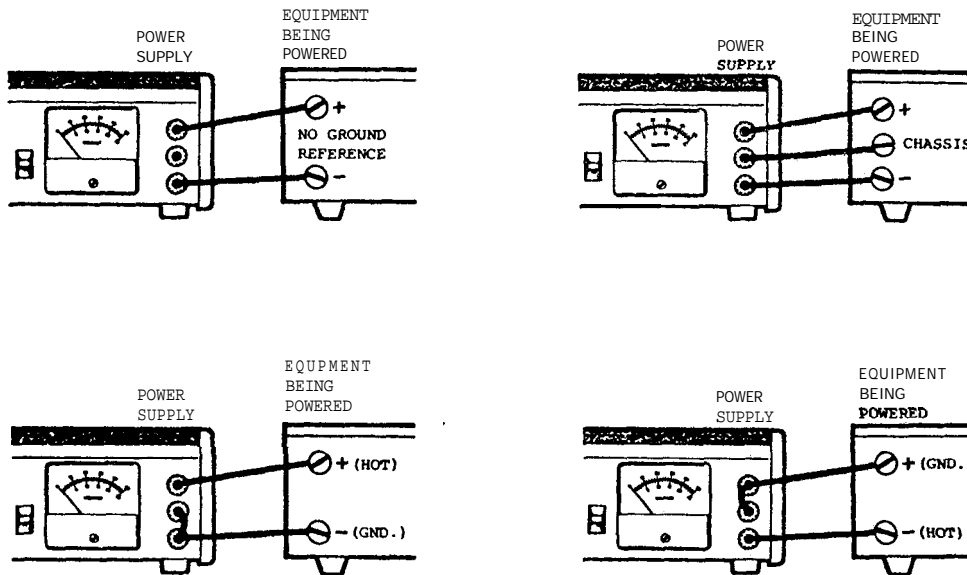

Figure 3. Power Supply Interconnect Possibilities

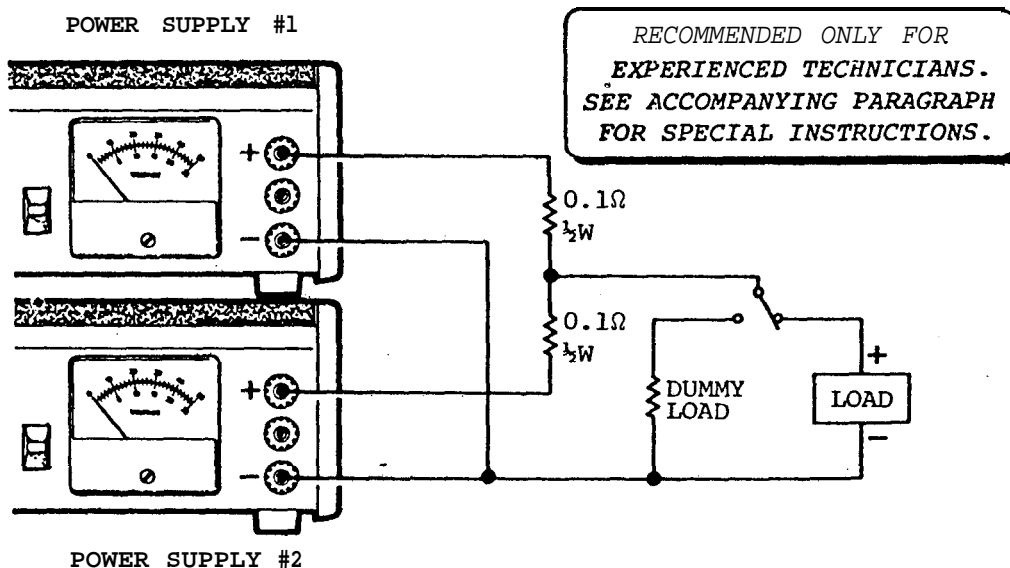

Figure 4. Two Power Supplies Connected in Parallel for 4 Amp Output

be determined with audio output: otherwise, the overload circuit will be activated upon reception of audio.

Some of the vehicular equipment listed may require more than 2 amperes of load current. This is especially true of transceivers during the transmitting mode and some tape players in the track change mode. If you have only occasional need to service such equipment, another power supply is not necessarily required. A vehicular battery of the correct voltage and of sufficient capacity will suffice. During testing, the transmitter does not normally need to be keyed except for short periods. The battery will provide adequate power for such testing. The power supply can be used as a battery charger to restore the battery to full charge, and all non-transmit testing can be done using the power supply as the dc power source.

Refer to Figure 4. Although it is possible to obtain up to 4 amperes load current from two power sup

quired for bench testing modules. Figure 5 shows a typical test set-up. Connect the (+) and (-) outputs of the power supply to the (+) and (-) power terminals of the module. Identical power is sometimes required at two or more terminals of a module. If so, jumper together these terminals. An earth ground may or may not be required. A test hook-up diagram for bench testing the module should be obtained. It should specify the operating voltage and current limit. The current limit will typically be lower than those previously described for battery operated and vehicular equipment, since only a single module is being powered.

Module testing is more likely to require two separate dc voltages simultaneously. Refer to the next paragraph for information.

USING TWO POWER SUPPLIES FOR TWO OUTPUT VOLTAGES

When two separate dc voltages are required

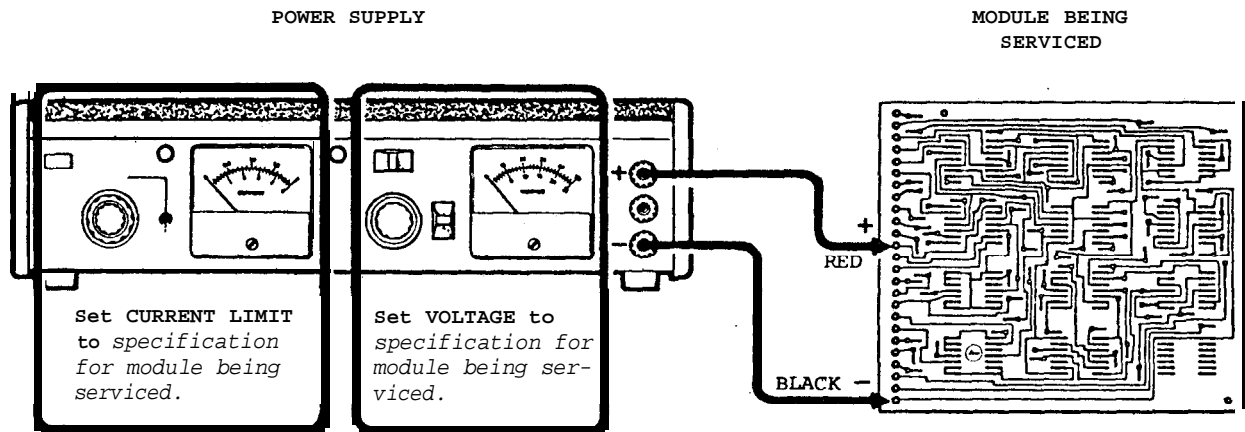

Figure 5. Typical Power Supply Connection to Module For Bench Testing

plies connected in parallel, it is not recommended except for use by highly experienced personnel. The power supplies should not be connected directly in parallel, but should be isolated by very low resistance so that balance is not so critical. Even with this technique, the power supplies must be well balanced or the unit carrying the heavier load will overload and turn off, which, in turn, will cause the other Power supply to overload and turn off. It is very difficult to bring the power supply output of both units up to operating voltage without disturbing the balance. One method to achieve balance is to use an external switching arrangement which allows selection of the load or a dummy load. The dummy load should be selected to draw approximately 1 ampere at the operating voltage of the main load: 1/2 ampere from each power supply. The Power supplies can be accurately balanced into the **dummy** load without fear of overload, then switched to the main load.

SERVICING PLUG-IN MODULES

Equipment containing plug-in modules is often repaired by replacing a malfunctioning module. Then servicing the defective module on the bench. A dc Power source such as this power supply is re-

quired for testing equipment, two power supplies may be used. Set the voltage and current limit for each power supply independently as required by each circuit. Only the circuit reference point must be common between the two supplies.

Figure 6 shows some typical examples of proper power supply connections when using two units. Take extra precaution to prevent reverse polarity connections in such situations. The numerous connections can become confusing. Additional colors for the test leads will be helpful. The power supplies are protected from reverse polarity damage from an external voltage source (such as the other power supply).

TWO POWER SUPPLIES IN SERIES FOR 0-100 VOLT OUTPUT

The power supplies may be connected in series for output voltages over 50 volts at 0 to 2 amperes. Figure 7 shows the correct connections. Set the current limit for both supplies at the same value and equalize the voltage between the two units. Since both units are connected in series, an overload in either unit will shut down the output from both supplies. The power supplies are built to permit stacking when two units are used.

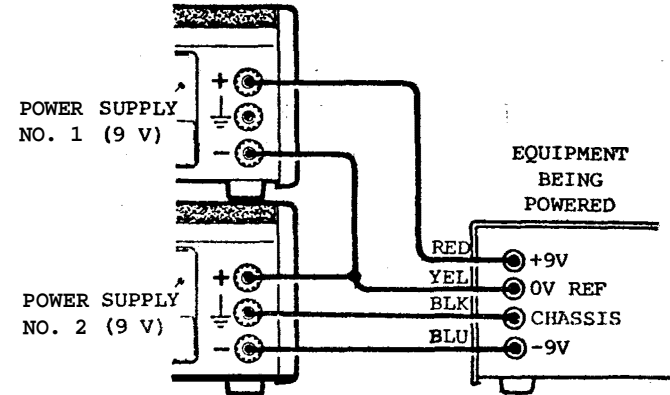
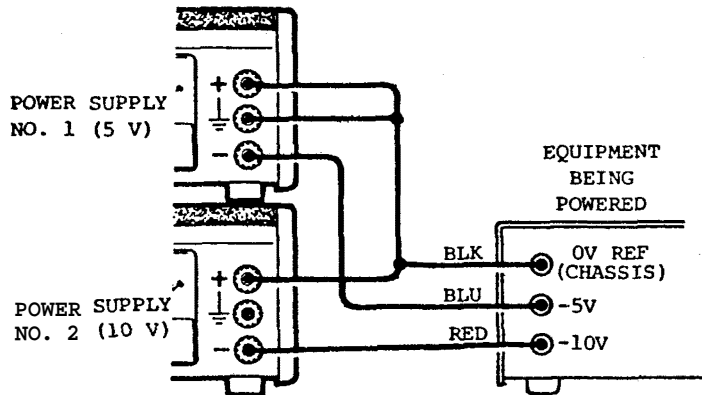
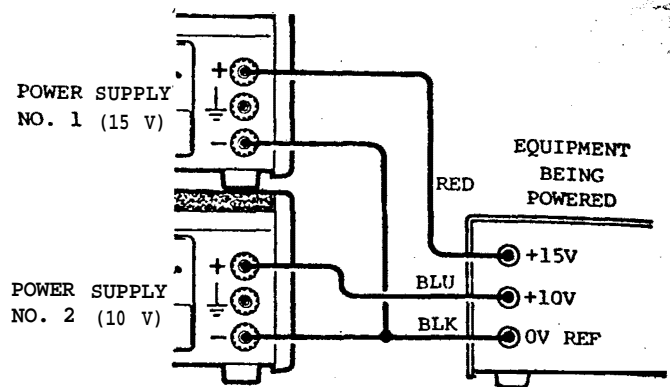
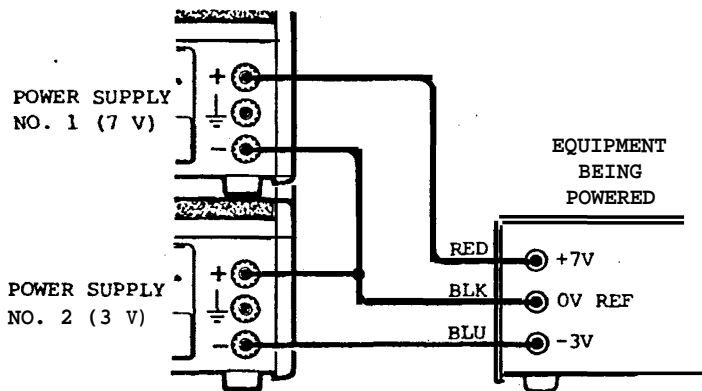

Figure 6. Using Two Power Supplies for Two Output Voltages (Typical Examples 1)

USING THE POWER SUPPLY AS A BATTERY CHARGER

The power supply can be used as a battery charger to restore the charge in rechargeable batteries such as lead-acid, nickel-cadmium and some alkaline types. Refer to the battery manufacturer's charging specifications for proper voltage and current settings. Charging information is often printed on the batteries. For batteries that specify maximum charge currents of less than 2 amperes, set the current limit to the specified value. For batteries with higher charge current capacities, set the current limit to maximum. The charging current of a battery is highest when the charger (power supply) is initially connected. As a result, current overload can occur before voltage is brought up to specified charging voltage. If this happens, reduce the power supply voltage slightly so the power supply does not shut down. After a period of time, increase the voltage until the full charge value can be obtained without shutdown.

OTHER SERVICING APPLICATIONS

The instrument can be used as a bias supply to test the effects of varying the dc bias, such as the AGC bias in a television receiver. Typically, the equipment being tested contains its own power supply and operates from ac power. DC voltages are present in the circuits. The power supply is floated from an appropriate point in the circuit, such as the emitter of a transistor. The power supply output is then applied to another point, such as the base of that transistor. Varying the power supply voltage then varies the dc bias on that stage, and the effects

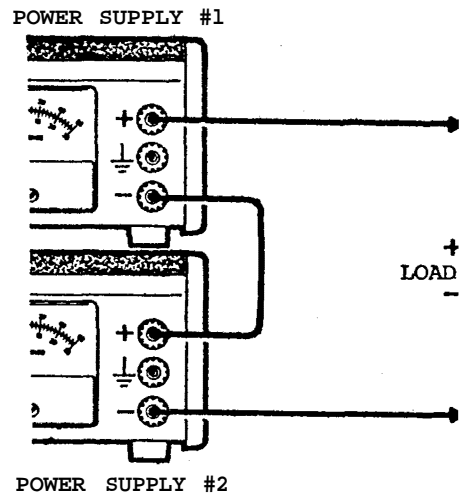

Figure 7. Two Power Supplies in Series for Cl-100 Volt Output

may be noted. A series limiting resistor is often used to protect circuits from overdissipation.

ELECTRONICS MANUFACTURING

In electronics manufacturing, the power supply is most often used as a dc power source to test completed units for proper operation and compliance with specifications. The instrument could also be used in incoming inspection to test purchased equipments or subassemblies. The use of the power supply for testing complete units is very similar to that previously described for servicing battery op

erated and vehicular equipment, while its use for testing subassemblies is very similar to that described for servicing modules.

This power supply is particularly well suited for manufacturing applications because of its ease of operation and the speed at which it will accomplish its job, in addition to its other features. When load current or total power dissipation are among the main characteristics to be measured, the total load current and voltage are instantly displayed on the two meters. The current limit can be adjusted so that all units which do not meet the load current specification will cause the overload to trip, and the unit can be rejected.

ELECTRONICS DESIGN ENGINEERING

The technician or engineer working in an engineering laboratory requires a power supply to power prototype and experimental circuits. This power supply is ideal because it monitors both current and voltage simultaneously, limits current to protect the circuit, is adjustable over such a wide range, and has excellent regulation and very low ripple.

Use of the instrument in an engineering laboratory is very similar to that previously described for servicing electronics equipment and modules, except that lower currents may be prevalent when powering single stage experimental circuits. The current limiting feature is very valuable in this application because it protects the unproven circuit from damage.

ELECTRONICS EDUCATION

The student in an electronics school may use the power supply for powering equipment and circuits as previously described for all other applications. In addition, the power supply will be used in the laboratory classroom to conduct experiments in fundamental electronics. In learning Ohm's law, for example, the relationships of resistance, current and voltage are vividly demonstrated by the use of the power supply. Being able to observe both the current and voltage meters simultaneously is a great aid in such experiments. Figure 8 shows typical examples of the types of experiments and exercises that may be conducted.

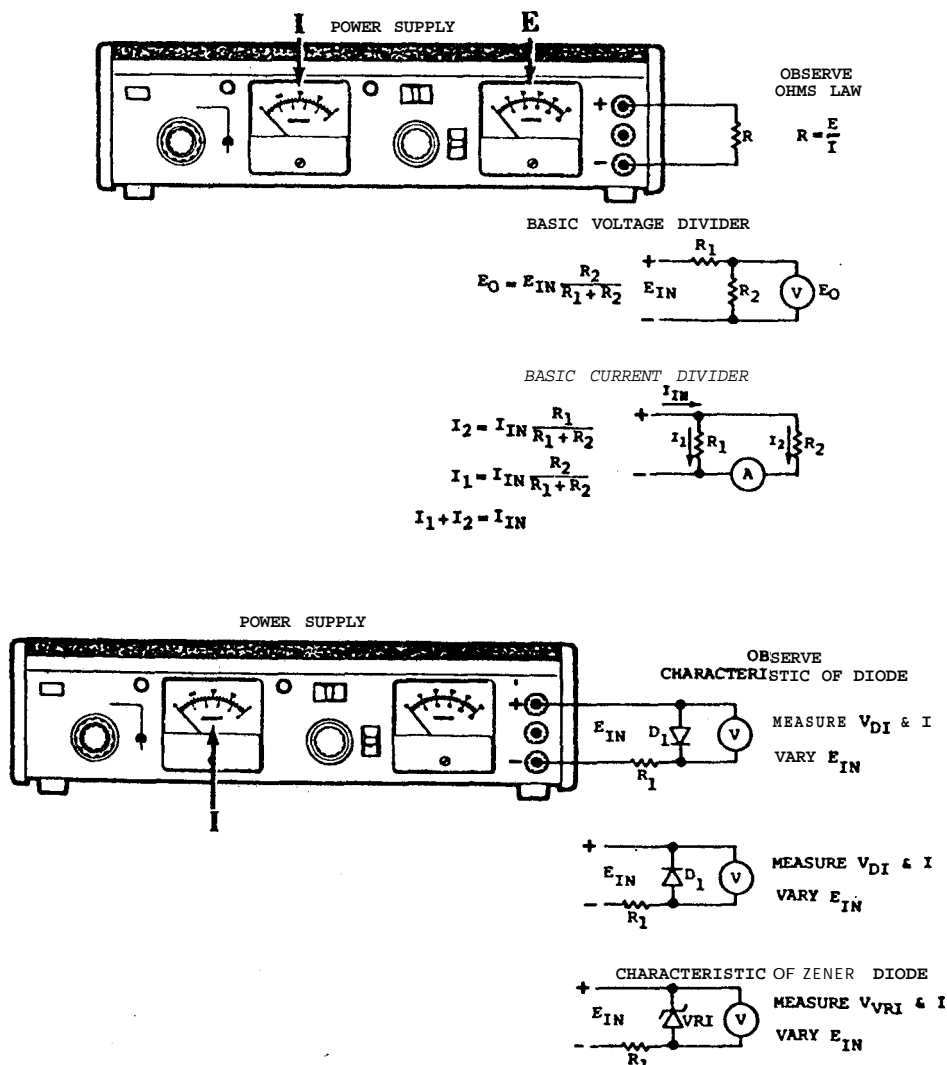

Figure 8. Typical Laboratory Classroom Experiments Using The Power Supply

CIRCUIT DESCRIPTION

GENERAL

The power supply converts a 117 VAC input to a highly regulated and filtered dc output that is fully adjustable from 0 to 50 volts and 0 to 2 amperes. The circuits that accomplish this action may be divided into five main groups as follows:

- Unregulated B+ Source. Converts the ac input into a raw, unregulated dc voltage.
- V+ and V- Source. Converts the ac input to +15 VDC (V+) and -15 VDC (V-) for powering active elements IC1 and IC2 in the control circuits and control sensing circuits group.
- Control Circuits. Controls the unregulated B+ source to provide a highly regulated B+ output that is adjustable from 0 to 50 volts.
- Current Sensing Circuits. Establishes the current limit, senses the load current, and activates an overload detector that shuts down the power supply if the current limit is exceeded.
- Metering. Monitors the output voltage and current.

Refer to Figure 9, the functional diagram, and to the schematic diagram. Circuit descriptions make constant reference to these diagrams.

NOTE

The voltages in the following circuit descriptions, and on the diagrams, are measured with respect to the regulated B+ output (the + terminal). Note that this point is floating independent of the chassis of the power supply.

UNREGULATED B+ SOURCE

The unregulated B+ source circuit converts the 117 volt ac input to a raw, unregulated B+ output. Later, in the control circuits, the unregulated B+ is converted into the regulated B+ output of the power supply.

The unregulated B+ output level is pre-regulated in coarse steps. As the LEVEL control is rotated clockwise from zero to maximum, the unregulated B+ voltage changes from its lowest to its highest value in four steps. This minimizes the difference between the unregulated B+ and the regulated B+ output, which always keeps power dissipation within safe limits.

The main components which make up this circuit are power transformer T1, pre-regulator switch assembly S5, bridge rectifier BR1, and filter capacitor C8.

The ac input is applied to the unregulated B+ circuit through on-off switch S4 (which is part of the LEVEL control), across neon POWER lamp NE1 (which glows continuously as a pilot lamp to show that power is on), to power transformer T1. Power transformer T1 has four taps in its main power output winding. At the lowest voltage setting, only the low voltage portion of the transformer is connected into the rectifier (this is the condition shown on the schematic diagram). As the LEVEL control is rotated clockwise, cams operate microswitches S5-C, then S5-B, and finally S5-A. Each cam-operated microswitch selects another tap on the secondary of the power transformer and sequentially steps the rectifier input voltage to a higher value.

Bridge rectifier BR1 converts the ac power to full wave dc, which is filtered by C8. The unregulated B+ output at C8 is regulated and filtered by the control circuits.

V+ AND V- SOURCE

The V+ and V- source is a completely separate power source for powering comparator IC1, and voltage reference and error amplifier IC2. These circuits must be free from the extreme voltage variations found in the other power source circuits.

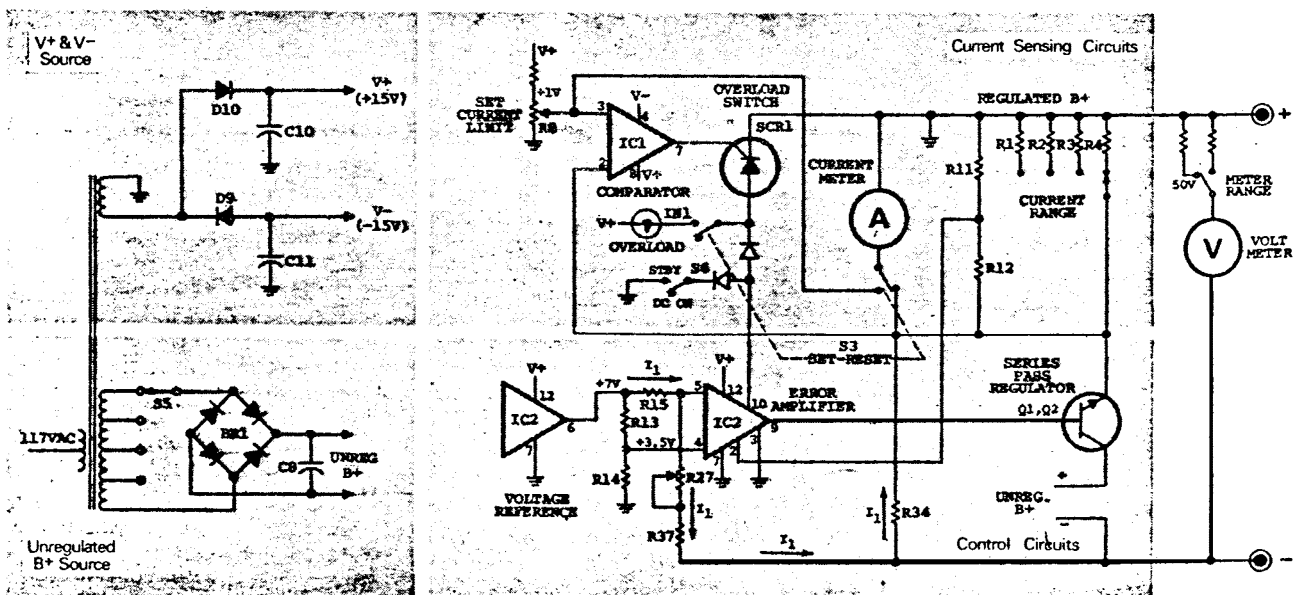

Figure 9. Power Supply Functional Diagram

The control Power winding of T1, diodes D9 and D10, and filter capacitors C10 and C11 form the V+ and V- voltage source. These power source Circuits provide + 15 and -15 volts respectively. Both the V+ and V- voltages float with respect to the regulated output, and are also independent of the variable unregulated B+ voltage.

CONTROL CIRCUITS

The control circuits convert the unregulated B+ voltage into the regulated B+ voltage. The control circuits establish the regulated B+ level in response to the **setting of LEVEL** control R27. When R27 is set for 0 volts, the following circuit conditions exist:

- **Voltage** reference IC2 provides a stable +7 V reference at IC2-6.
- The +7 V reference is divided across R13 and R14 to **place** +3.5 V on the inverting input (pin 4) of error amplifier IC2.
- The regulated B- output voltage is 0 V.
- The +7 V reference is divided across current path I₁, which consists of R15, R27 (Approximately 0 ohms at this time), R37 and R34. This places approximately +3.5 volts on the non-inverting input (pin 5) of error amplifier IC2.
- **Since** the inverting and non-inverting inputs to IC2 are equal, no output is developed at IC2-9.
- **No** drive is applied to series pass regulator Q1, Q2 and the output remains at zero volts.

When LEVEL control R27 is increased to a higher voltage level, the following circuit action occurs:

- **The** resistance of R27 is added to the voltage divider network, decreasing current I₁.
- **The** voltage at IC2-5 increased (less drop across R15), and error amplifier IC2 produces an output which biases regulator Q1, Q2 into operation.
- **The** regulator allows some of the unregulated B+ to pass to the output terminals and the output voltage rises.
- **As** the output voltage rises, the B- becomes more negative.
- Current I₁ increases as B- becomes more negative, and the voltage at IC2-5 decreases until balance is achieved.

When LEVEL control R27 is decreased, the opposite action occurs. Once R27 is set and balance is achieved, any load current changes that tend to change the output voltage are sensed and corrected.

CURRENT SENSING CIRCUITS

The major components in the current sensing circuit's are comparator IC1, overload switch SCR1, and current sensing resistors R1 thru R4. These circuits monitor the load current and shut down the power supply if the preset current limit is exceeded.

First, let us examine the current sensing resistors R1 thru R4. These precision, low value resistors are in series with the output load current. The values are chosen so that the maximum current for a chosen range Produces exactly 1 **volt drop across the resistor** (for example, if the 2A range is selected 2 amps through resistor R4 develops exactly 1

volt). The voltage developed across the current sensing resistor is applied as the non-inverting input (pin 2) to comparator IC1.

The inverting input at pin 3 of comparator IC1 is a 0 to 1 volt dc potential selected by the SET CURRENT LIMIT control R8.

Whenever the output load current produces a voltage drop across the selected current sensing resistor (R1 thru R4) that is greater than the preset voltage on the inverting input of IC1, a Positive output voltage of approximately 1 volt appears at the output (pin 7) of comparator IC1. This voltage drives the gate of overload switch SCR1 and turns it on. Overload switch SCR1 grounds pin 10 of error amplifier IC2, which inhibits its operation regardless of all other inputs and shuts down the power supply. SCR1 also provides the ground path which allows the OVERLOAD lamp to light. Set/reset switch S3 opens the voltage path to SCR1 to reset it to an off condition.

The STBY-DC ON switch (S6) is also connected to pin 10 of error amplifier IC2. In the STBY position, this switch grounds IC2-10 and inhibits its operation, thus disabling the power supply output.

METERING

Voltmeter M1 is connected directly across the output terminals to measure output voltage. Series resistors, as selected by METER range switch S2, calibrate the meter to read 0-25V or 0-50V. A mechanical interlock prevents the LEVEL control from being increased above approximately 25 volts when S2 is in the 0-25V range.

Current meter M2 is actually a voltmeter that is calibrated to accurately measure output load current. The meter measures the voltage that is developed across the current sensing resistor, which is exactly 1 volt for a full scale meter reading. When setting the current limit, switch S3 is actuated, which connects the current meter directly across the SET CURRENT LIMIT control R8. This control selects a voltage from 0 to 1V, which very accurately corresponds to the current limit value read on the meter.

MAINTENANCE AND CALIBRATION

WARNING — THE FOLLOWING INSTRUCTIONS ARE FOR USE BY QUALIFIED PERSONNEL ONLY. TO AVOID ELECTRICAL SHOCK, DO NOT PERFORM ANY SERVICING OTHER THAN THAT CONTAINED IN THE OPERATING INSTRUCTIONS UNLESS YOU ARE QUALIFIED TO DO SO.

This power supply is built to provide long, trouble-free service and does not require periodic maintenance. If the unit malfunctions, use conventional troubleshooting techniques, such as voltage and resistors checks, to isolate the defective component. If electrical components are replaced, the unit should be recalibrated.

CALIBRATION

To gain access to the calibration adjustments, remove the 3 screws at the rear of the top cover, then lift the top cover at the rear and slide the front lip of the cover from the retaining bosses on the front panel. Refer to Figure 10 for locations of calibration adjustments.

MAX OUTPUT ADJ (R24)

1. Connect an accurate, calibrated voltmeter to the output terminals of the power supply.
2. Set the LEVEL control of the power supply to maximum.
3. Adjust the MAX OUTPUT ADJ potentiometer (R24) for exactly 50.5 volts on the external voltmeter.

25V CAL (R33)

1. Connect an accurate, calibrated voltmeter to the output terminals of the power supply.
2. Set the METER RANGE switch of the power supply to the 25V position.
3. Adjust the LEVEL control of the power supply for exactly 20 volts on the external voltmeter.
4. Adjust 25V CAL potentiometer (R33) for exactly 20 volts on the voltmeter of the power supply.

50V CAL (R30)

1. Connect an accurate, calibrated voltmeter to the output terminals of the power supply.
2. Set the METER RANGE switch of the power supply to the 50V position,
3. Adjust the LEVEL control of the power supply for exactly 50 volts on the external voltmeter.
4. Adjust 50V CAL potentiometer (R30) for exactly 50 volts on the voltmeter of the power supply.

CURRENT METER CAL (R-29)

1. Connect an accurate, calibrated ammeter capable of 2A in series with an appropriate load (1 ohm, 4 watts) to the output terminals of the power supply.
2. Adjust the LEVEL control of the power supply for exactly 2A on the external ammeter.
3. Adjust CURRENT METER CAL potentiometer (R29) for exactly 2A on the current meter of the power supply.

INTERNAL CURRENT LIMIT ADJ. (R-21)

1. Turn SET CURRENT LIMIT (3) to full C.W.
2. Adjust R-21 to full scale when pressing the set/reset button (4).

FUSE REPLACEMENT

If there is no power supply output and the POWER lamp does not light, check fuse F1. The fuse F1 is located inside the cabinet, which is made accessible by removing the 3 screws at the rear of the top cover, then lifting the top cover at the rear to slide the front lip of the cover from the retaining bosses on the front panel.

Fuse F1 is soldered to a terminal strip at the right of the main power transformer. Figure 10 shows the location of the fuse.

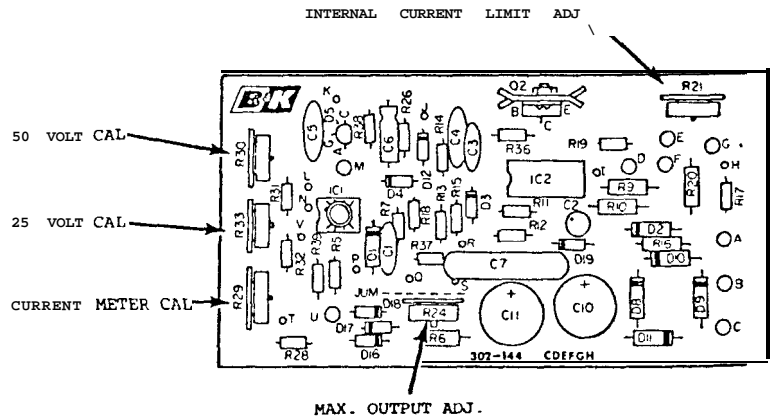
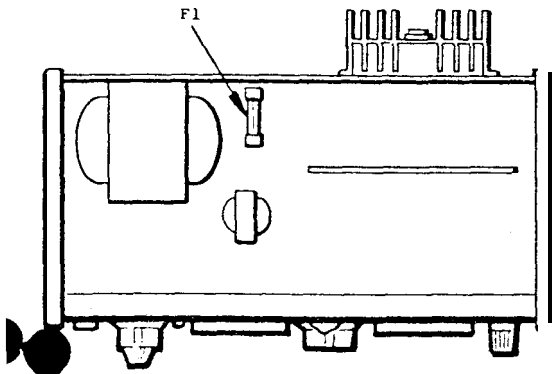
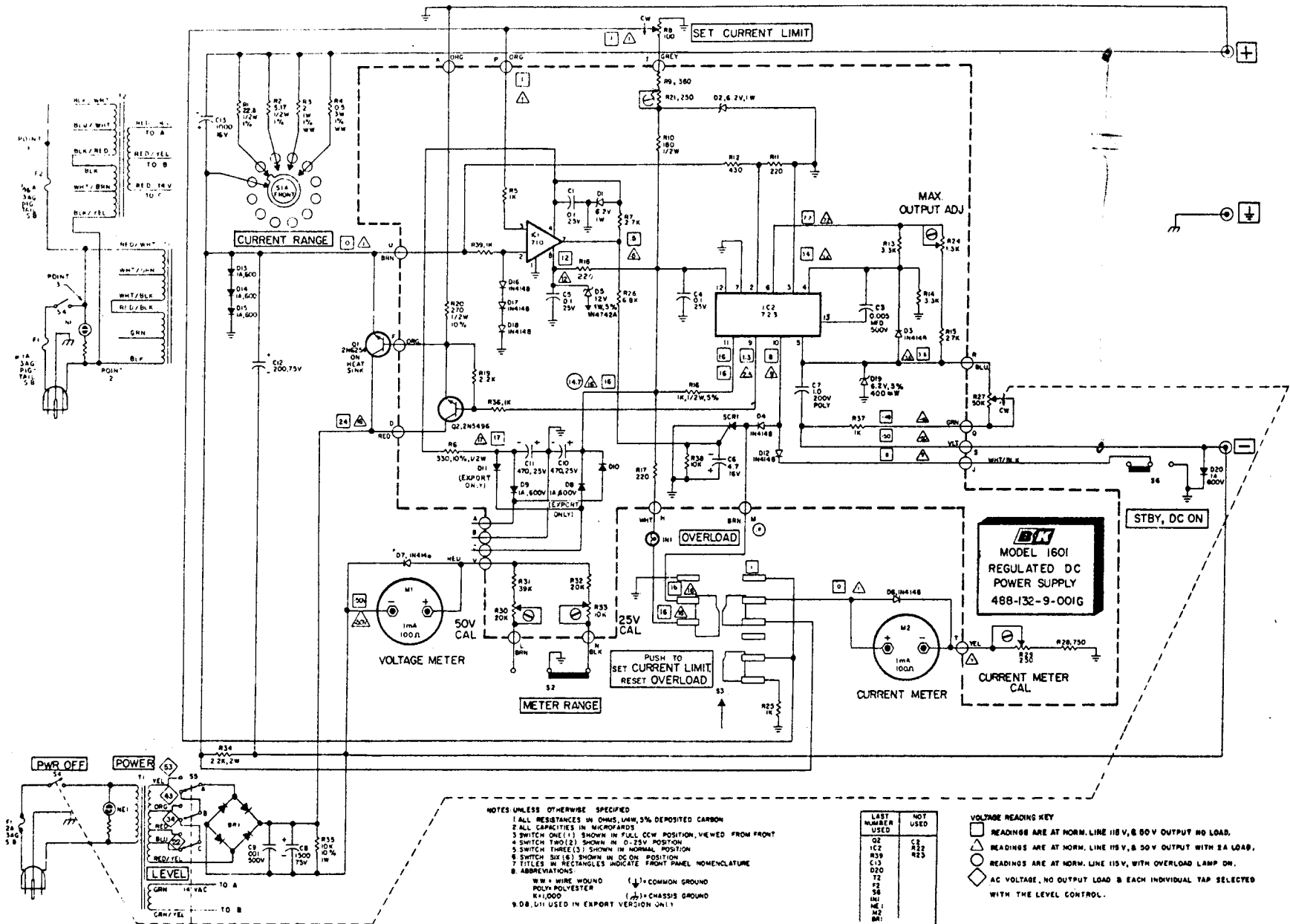

Figure 10. Location of Calibration Adjustments and Fuses



NOTES UNLESS OTHERWISE SPECIFIED
 1 ALL RESISTANCES IN OHMS, UNLESS OTHERWISE SPECIFIED
 2 ALL CAPACITIES IN MICROFARADS
 3 SWITCH ONE (1) SHOWN IN FULL CW POSITION, VIEWED FROM FRONT
 4 SWITCH TWO (2) SHOWN IN 0.25V POSITION
 5 SWITCH THREE (3) SHOWN IN NORMAL POSITION
 6 SWITCH SIX (6) SHOWN IN DC ON POSITION
 7 TITLES IN RECTANGLES INDICATE FRONT PANEL NOMENCLATURE
 8 ABBREVIATIONS:
 WW = WIRE WOUND () = COMMON GROUND
 PP = POLYESTER () = CHASSIS GROUND
 K = 1,000 () = CHASSIS GROUND
 9.08, D11 USED IN EXPORT VERSION ONLY

LAST NUMBER USED	NOT USED
Q2	C8
IC2	R22
R39	R23
C13	
D20	
T2	
F2	
S6	
IM1	
M2	
BR1	

VOLTAGE READING KEY
 □ READINGS ARE AT NORM. LINE 115 V, & 50V OUTPUT NO LOAD.
 △ READINGS ARE AT NORM. LINE 115 V, & 50V OUTPUT WITH 2A LOAD.
 ○ READINGS ARE AT NORM. LINE 115 V, WITH OVERLOAD LAMP ON.
 ◇ AC VOLTAGE, NO OUTPUT LOAD & EACH INDIVIDUAL TAP SELECTED WITH THE LEVEL CONTROL.

ALTERNATE WIRING

F1 VALUE	LINE VOLTS	T1 PRIMARY CONNECTIONS	T2 PRIMARY CONNECTIONS
2A	55-110 V	REMOVE JUMPER WHI/BLK - RED/BLK CON-PT 3 TO WHI/GRN & GRN CON-PT 2 TO WHI/BLK & BLK	REMOVE JUMPER BLK/RED/RED CON-PT 1 TO BLU/WHI & WHI/BRN CON-PT 2 TO BLU/RED & BLK/YEL
2B	105-225 V	REMOVE JUMPER WHI/BLK - RED/BLK CON-PT 3 TO WHT/WHI & RED/BLK CON-PT 2 TO WHT/BLK & BLK	REMOVE JUMPER BLK/RED/RED CON-PT 1 TO BLK/WHI & BLK CON-PT 2 TO BLU/RED & BLK/YEL
1A	1-0-130 V		

B & K-PRECISION MODEL 1601 PARTS LIST

SCHEMATIC SYMBOL	DESCRIPTION	B & K-PRECISION PART No.
CAPACITORS		
C1, 4, 5	0.1 mfd, 25V Ceramic Disc Capacitor020-110-9-001
C3	0.005 mfd, ±20%, 500V, Disc Capacitor020-018-9-001
C6	4.7 mfd, 16V Electrolytic Capacitor022-104-9-001
C7	1 mfd, 200V, 10% Polyester Capacitor025-021-9-001
C8	1500 mfd, 75V Electrolytic Capacitor022-113-9-001
C9	.001 mfd, 500V, 10% Ceramic Disc Capacitor020-051-9-001
C10, 11	470 mfd, 25V, P.C. Electrolytic Capacitor022-095-9-001
C12	200 mfd, 75V Electrolytic Capacitor022-094-9-001
C13	1000 mfd, 16V Electrolytic Capacitor022-058-9-001

CONTROLS & RESISTORS

R1	22.8Ω, ½W, 1% Deposited Carbon Resistor002-029-9-001
R2	5.17Ω, ½W, 1% Deposited Carbon Resistor002-028-9-001
R3	2Ω, 1W, 1% Wirewound Resistor006-001-3-020
R4	0.5Ω, 3W, 1% Wirewound Resistor004-129-9-001
R21, 29	250Ω Trimpot008-067-9-001
R24	1.5KΩ Trimpot008-127-9-001
R27	50KΩ Potentiometer (includes SW-4)008-191-9-001
R30	20KΩ Trimpot008-139-9-001
R33	10KΩ Trimpot008-058-9-001

SWITCHES

S1	Rotary Switch, 4 position (includes R-8 Potentiometer)	.083-144-9-001
S2, 6	Slide Switch, D.P.D.T.084-014-9-001
S3	Push Button, Momentary088-015-9-001
SSa, b, c	Snap Action (Micro)086-001-9-001

SEMICONDUCTORS

D1, 2	Diode, Zener, 6.2V, 1W, 5% (1N4735A)152-037-9-001
D3, 4, 6, 7 12, 16, 17, 18 }	Diode, Silicon (1N4148)151-038-9-001
D5	Diode, Zener, 12V, 1W, 5% (1N4742A)152-039-9-001
D8, 9, 10, 11 13, 14, 15, 20 }	Diode, Silicon, 1 Amp, 600V151-050-9-001
D19	Diode, Zener, 6.2V, 400mW, 5% (1N753A)152-071-9-001
BR1	Bridge Rectifier, Silicon157-002-9-001
SCR1	Thyristor, SCR181-002-9-001
IC1	710C Integrated Circuit307-017-9-001
IC2	723C Integrated Circuit307-009-9-001
Q1	Transistor, Silicon Power, NPN172-015-9-001
Q2	Transistor, Silicon Power, NPN172-016-9-001

B & K-PRECISION MODEL 1601 PARTS LIST

SCHEMATIC SYMBOL	DESCRIPTION	B & K-PRECISION PART No.
------------------	-------------	--------------------------

MISCELLANEOUS

T1	Transformer, Power.065-101-9-001
T1 (export)	Transformer, Main065-084-9-002
T2 (export)	Transformer, Control Power.065-087-9-001
F1	Fuse, 2 Amp, 3AG, Pigtail Slo-Blo193-014-9-001
F1 (export)	Fuse, 1 Amp, 3AG, Pigtail Slo-Blo193-016-9-001
F2 (export)	Fuse, 1/16 Amp, 3AG, Pigtail Slo-Blo193-004-9-001
M1	Voltmeter (0-1 mA)320-047-9-001
M2	Current Meter (0-1 mA)320-048-9-001
	Mica Insulator (for Q1)347-002-9-001
	Shoulder Washer (for Q1, 2 req)347-004-9-001
	Strain Relief380-001-9-001
	Button, Red380-109-9-001
	Foot381-060-9-001
	Glamour Cap384-008-9-001
	Glamour Cap with White Line384-015-9-001
	Cam #1.380-200-9-001
	Cam #2.380-200-9-002
	Cam #3.380-200-9-003
	Cam #4.380-200-9-004
	P.C. Board Support, Plastic380-202-9-001
IN1	Incandescent Lamp400-029-9-001
NE1	Neon Lamp (with Resistor)401-001-9-002
	Line Cord420-013-9-001
	Star Washer (for Lens)731-008-9-001
	Heat Sink (Driver, Q2)747-023-9-001
	Heat Sink (Pass, Q1)747-024-9-001
	Jewel Lens (Red)750-003-9-001
	Knob751-101-9-001
	Knob751-102-9-001
	Knob751-103-9-001
	Binding Post Head, Black773-046-9-001
	Binding Post Washer, Black773-046-9-002
	Binding Post Head, Red773-047-9-001
	Binding Post Washer, Red773-047-9-002
	Binding Post Head, Green773-048-9-001
	Binding Post Washer, Green773-048-9-002
	Bushing 3/8-32x15/32849-017-9-001
	Top, Cover.253-025-9-903
	Case, Left Side271-020-9-001
	Case, Right Side.271-021-9-001
	Foam Tape (for Top Cover)344-014-9-001

NOTE: Standard value resistors and capacitors are not listed, values may be obtained from schematic diagram. Minimum charge \$5.00 per invoice. Orders will be shipped C.O.D. unless previous open account arrangements have been made or remittance accompanies order. Advance remittance must cover postage or express charge. Specify serial number when ordering replacement parts.